

Hydronic valve choice

Name	Car nominal speed m/s	Pump flow l/m	Type
HYDRONIC 300	Fino a 0,63	Fino a 250	Standard
HYDRONIC 300S	$0,63 < v \leq 1$	Fino a 250	Standard with inspection drive
LRV-1	Fino a 1	Fino a 650	Electronic valve
iValve	Fino a 1	Fino a 500	Electronic valve
EV 100	Fino a 1	Fino a 650	Standard
H250e	Fino a 1	Fino a 250	Electronic valve

Tank type

All the oil must fit inside the tank when the car is at the bottom (V max)

The motor must be completely submerged with the car at the top floor (V min)

Always check that:

$$V_{\min} + V_2 < V \quad (V_{\max})$$

V = oil in the tank; must be \leq V max

V₂ = oil volume required by jack stroke, jack cylinder and hose

See the diagram to find the quantity of oil needed, for the size and the stroke of jack.

Note: 1¼", L = 10 mt hose (8 liters) has been considered:

Tank type	Oil volume	
	V min.[l]	V max.[l]
MHY 8	55	135
MHY 8.0	50	135
MHY 15.0	65	215
MHY 25	100	340
MHY 37	280	650



Grafico selezione serbatoiserbatoi.drawio

Tank selection chart

Use the diagram according to the jack diameter selected.
 The oil volume needed can be found on the y axis of the diagram, with the jack stroke and size as parameters.

Note: 1¼", L = 10 mt hose (8 liters) has been considered

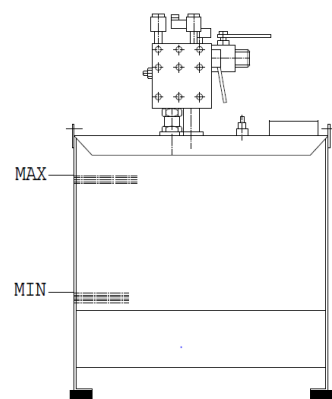

Grafico selezione serbatoi-eng.drawio

Power unit choice

In order to choose the right power unit size, check the required pump flow [litres/min] the motor power [kW] and oil tank capacity in the tables below.

STANDARD HYDRONIC 300 – 300S

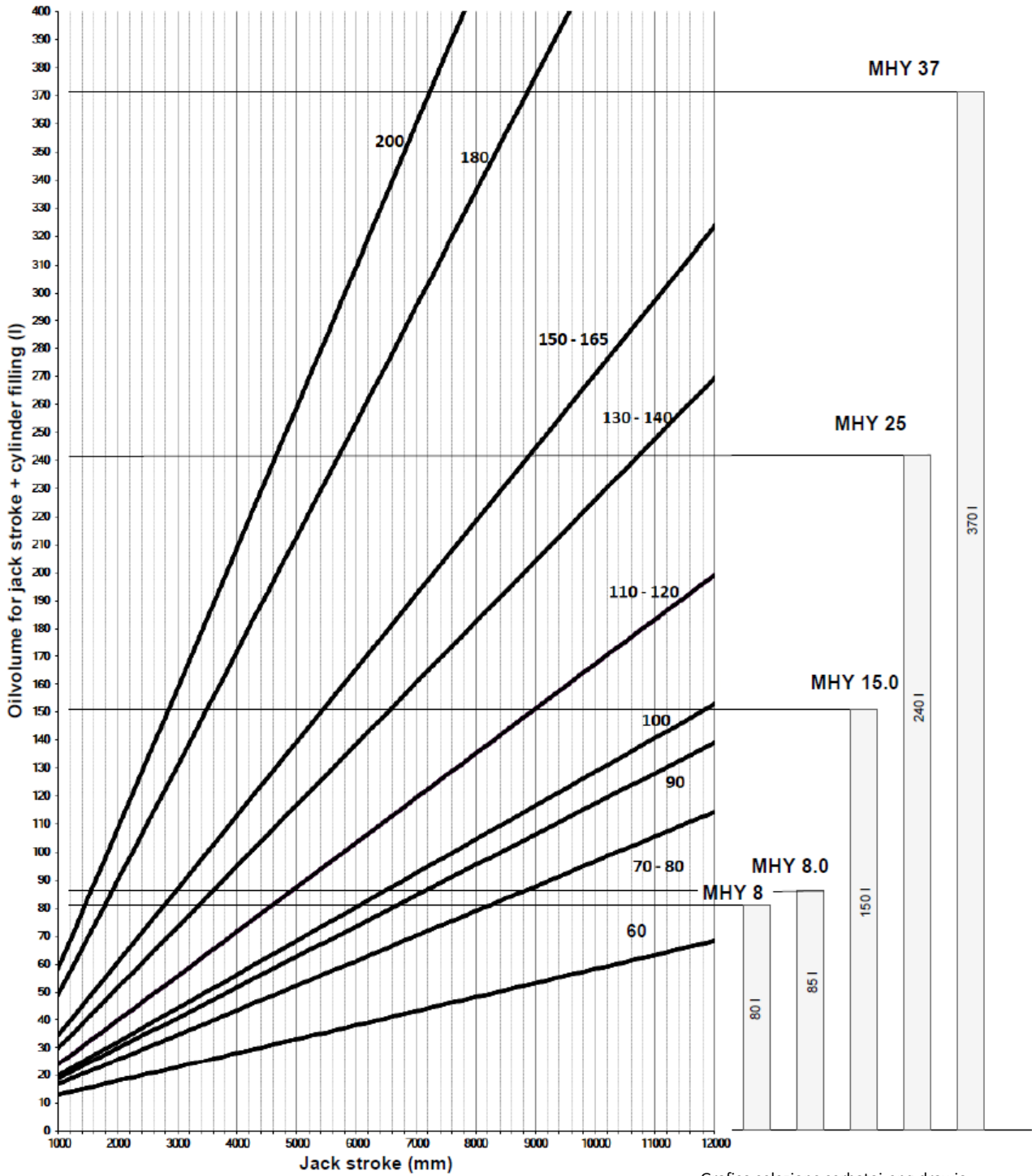
MOTOR POWER [kW]	PUMP FLOW [l/min]	POWER UNIT TANK
$3 \leq \text{kW} \leq 16$	$35 \leq \text{l/min} \leq 250$	MHY8.0
$3 \leq \text{kW} \leq 24$	$35 \leq \text{l/min} \leq 250$	MHY15.0
$3 \leq \text{kW} \leq 29$	$35 \leq \text{l/min} \leq 250$	MHY25
$3 \leq \text{kW} \leq 29$	$35 \leq \text{l/min} \leq 250$	MHY37

ELECTRONIC VALVE LRV-1

MOTOR POWER [kW]	PUMP FLOW [l/min]	POWER UNIT TANK
$3 \leq \text{kW} \leq 16$	$35 \leq \text{l/min} \leq 250$	MHY8.0
$3 \leq \text{kW} \leq 24$	$35 \leq \text{l/min} \leq 250$	MHY15.0
$3 \leq \text{kW} \leq 29$	$35 \leq \text{l/min} \leq 500$	MHY25
$3 \leq \text{kW} \leq 60$	$35 \leq \text{l/min} \leq 650$	MHY37

ELECTRONIC VALVE iValve

MOTOR POWER [kW]	PUMP FLOW [l/min]	POWER UNIT TANK
$3 \leq \text{kW} \leq 16$	$35 \leq \text{l/min} \leq 250$	MHY8
$3 \leq \text{kW} \leq 24$	$35 \leq \text{l/min} \leq 250$	MHY15.0
$3 \leq \text{kW} \leq 29$	$35 \leq \text{l/min} \leq 500$	MHY25
$3 \leq \text{kW} \leq 47$	$35 \leq \text{l/min} \leq 500$	MHY37

STANDARD EV 100

MOTOR POWER [kW]	PUMP FLOW [l/min]	POWER UNIT TANK
$3 \leq kW \leq 16$	$35 \leq l/min \leq 125$	MHY8.0
$3 \leq kW \leq 24$	$35 \leq l/min \leq 250$	MHY15.0
$3 \leq kW \leq 29$	$35 \leq l/min \leq 500$	MHY25
$3 \leq kW \leq 60$	$35 \leq l/min \leq 650$	MHY37

ELECTRONIC VALVE H250e

MOTOR POWER [kW]	PUMP FLOW [l/min]	POWER UNIT TANK
$3 \leq kW \leq 16$	$35 \leq l/min \leq 250$	MHY8.0
$3 \leq kW \leq 24$	$35 \leq l/min \leq 250$	MHY15.0

MHY 8 with iValve electronic valve power unit data

MOTOR POWER [kW]	PUMP FLOW [l/m]	Min oil volume [l]	Working oil volume [l]	Max oil volume [l]
$3 \leq Kw \leq 16$	$35 \leq l/m \leq 250$	55	80	135

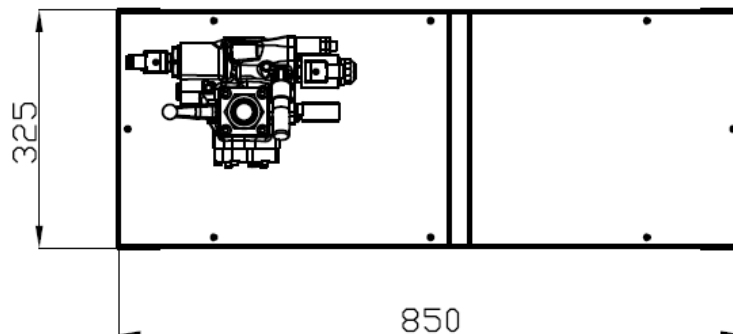
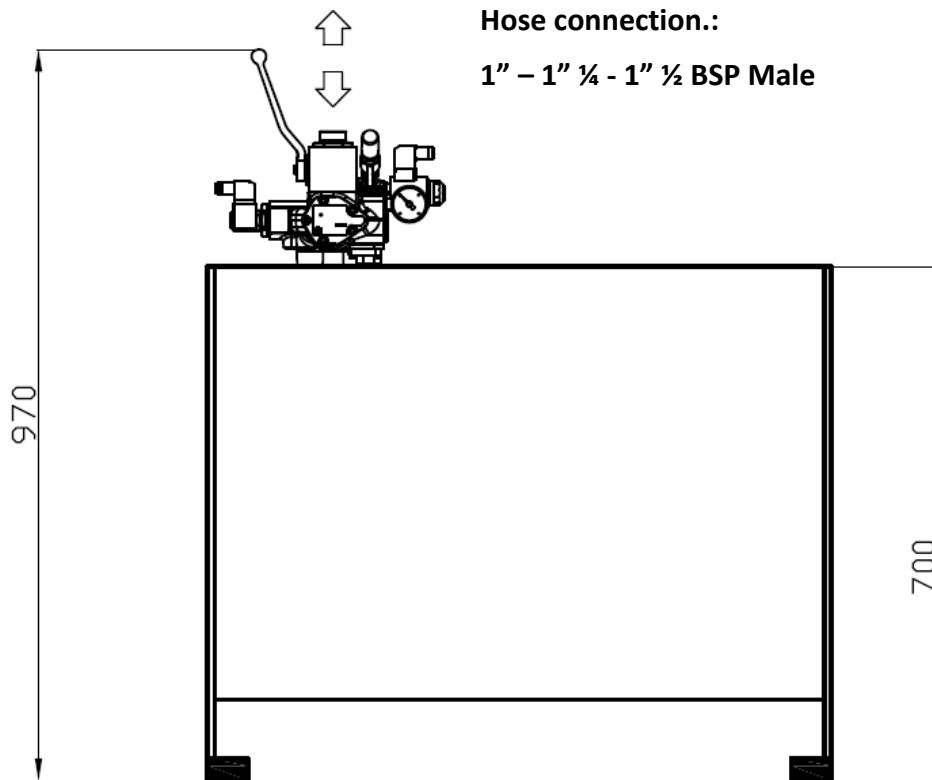

MHY 8.0 with H 300 and H 300S valve power unit data

MOTOR POWER [kW]	PUMP FLOW [l/m]	Min oil volume [l]	Working oil volume [l]	Max oil volume [l]
$3 \leq Kw \leq 16$	$35 \leq l/m \leq 250$	50	85	135

Hose connection.:

1" - 1" ¼ - 1" ½ BSP Male

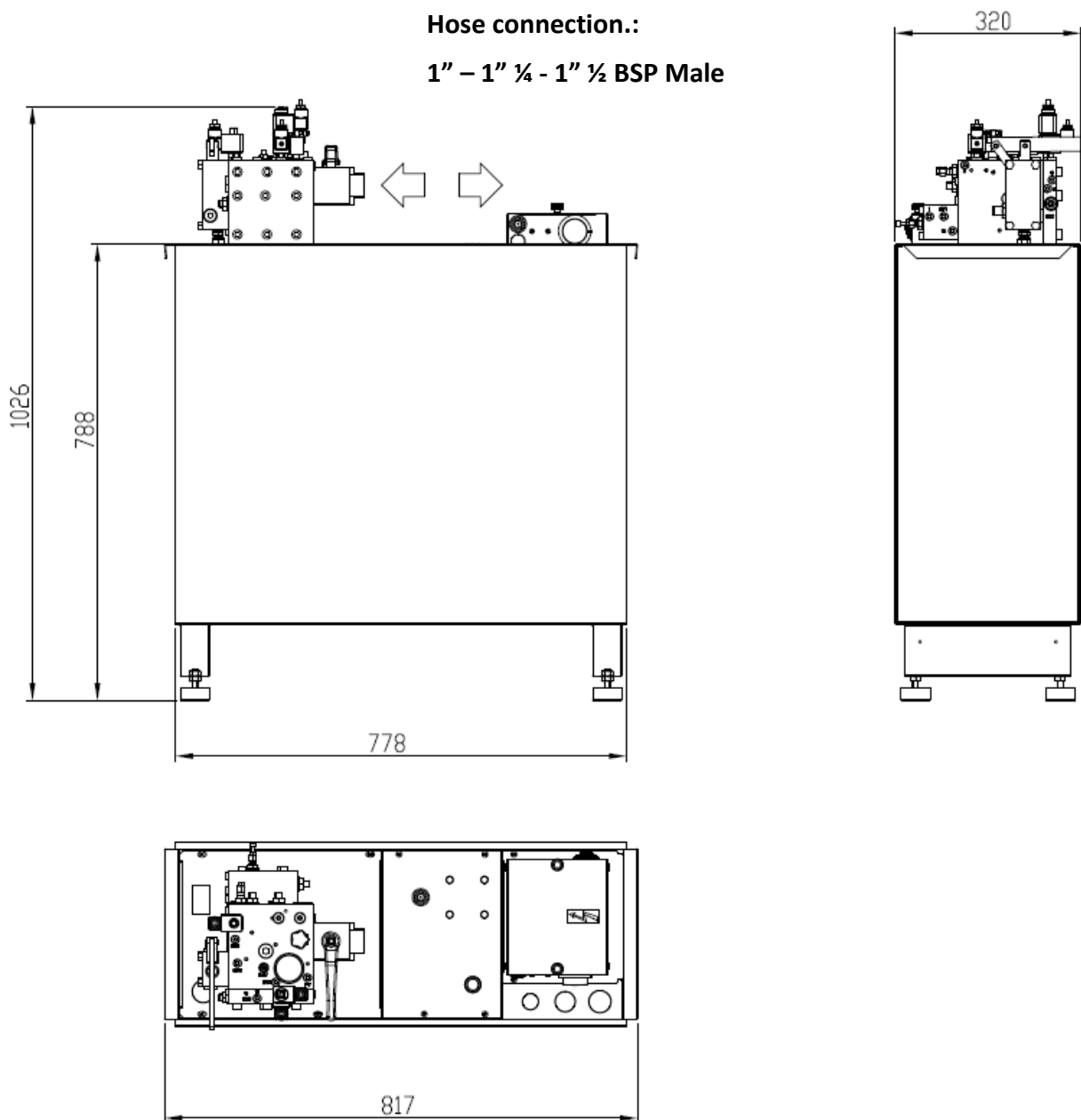

MHY 8.0 with LRV-1 electronic valve power unit data

MOTOR POWER [kW]	PUMP FLOW [l/m]	Min oil volume [l]	Working oil volume [l]	Max oil volume [l]
$3 \leq K_w \leq 16$	$35 \leq l/m \leq 250$	50	85	135

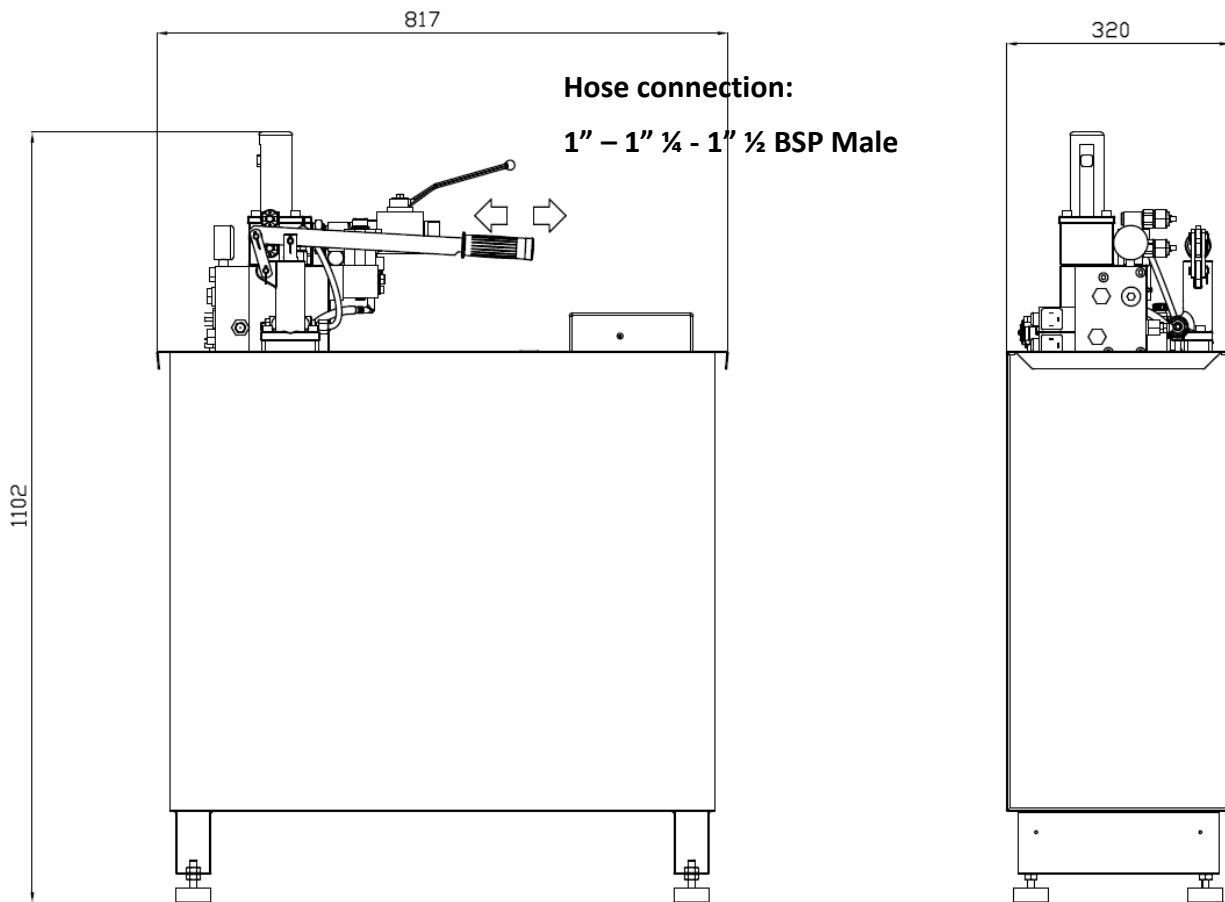

MHY8-0-LRV-1

MHY 8.0 with EV100 valve power unit data

MOTOR POWER [kW]	PUMP FLOW [l/m]	Min oil volume [l]	Working oil volume [l]	Max oil volume [l]
$3 \leq K_w \leq 16$	$35 \leq l/m \leq 125$	50	85	135

Hose connection:

1" – 1" ¼ - 1" ½ BSP Male

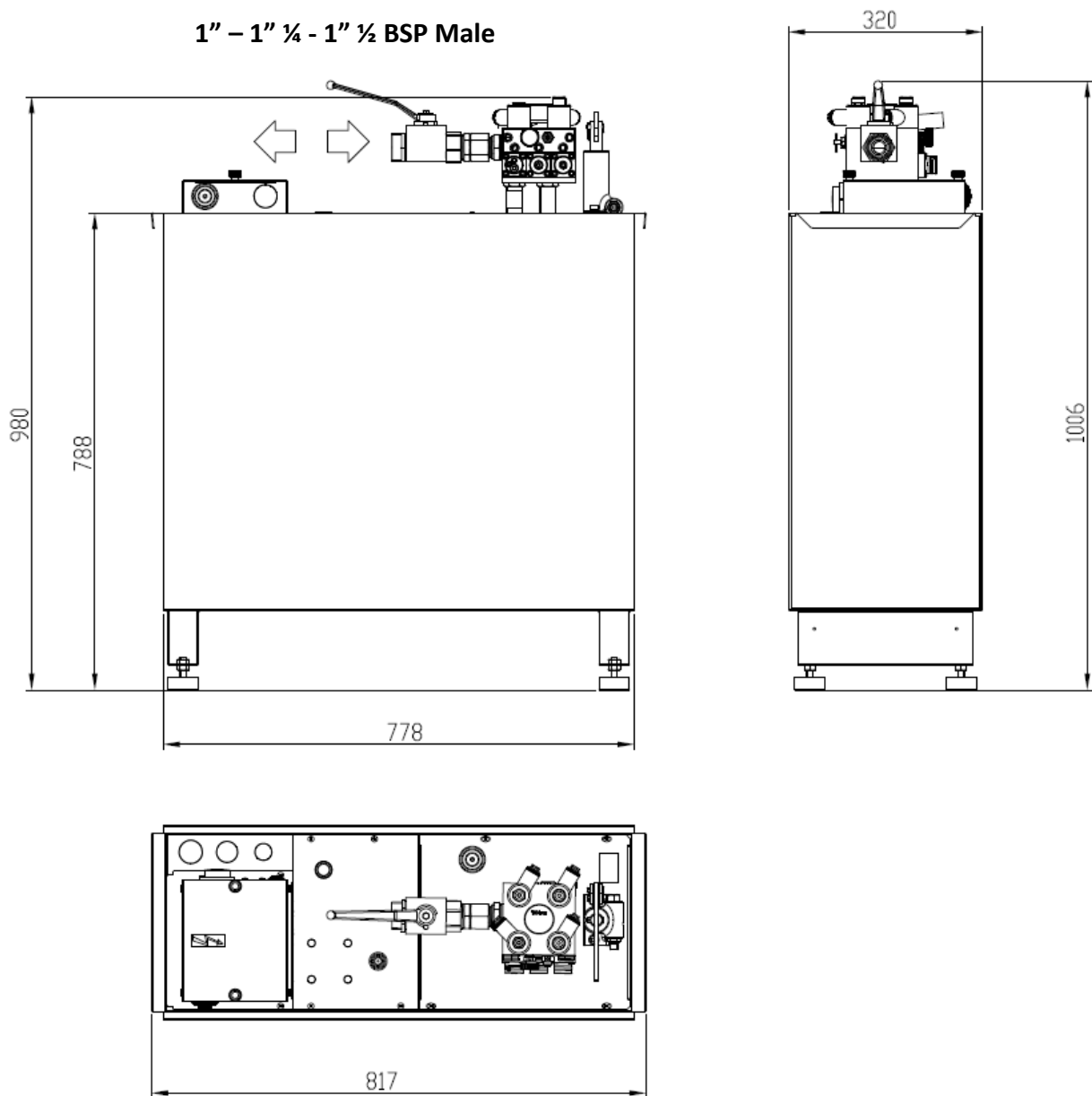

MHY 8.0 with H250e electronic valve power unit data

MOTOR POWER [kW]	PUMP FLOW [l/m]	Min oil volume [l]	Working oil volume [l]	Max oil volume [l]
$3 \leq K_w \leq 16$	$35 \leq l/m \leq 250$	50	85	135

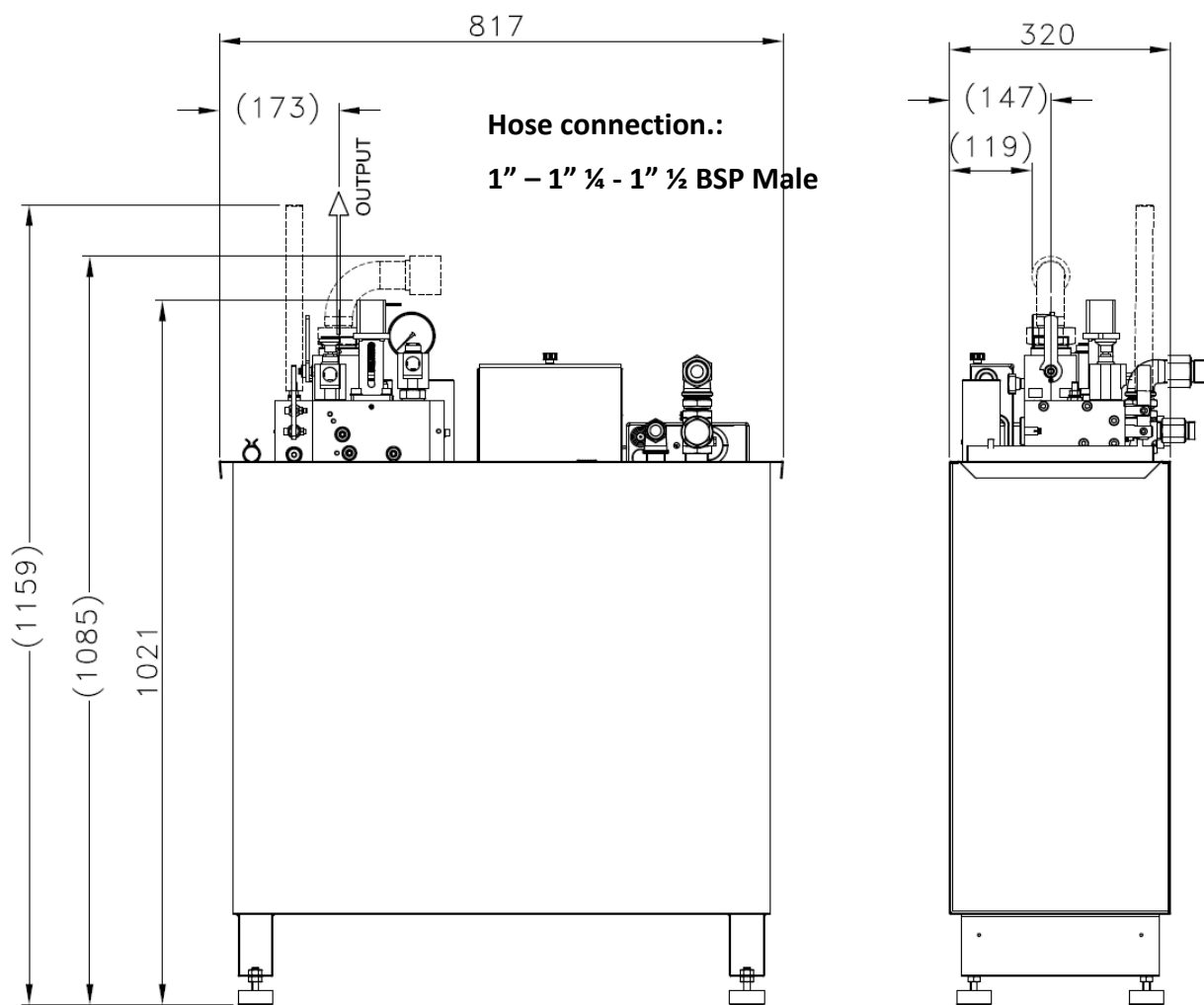

MHY8-0-H250E

MHY 15.0 with H300 and H300S valves power unit data

MOTOR POWER [kW]	PUMP FLOW [l/m]	Min oil volume [l]	Working oil volume [l]	Max oil volume [l]
$3 \leq K_w \leq 24$	$35 \leq l/m \leq 250$	45	150	195

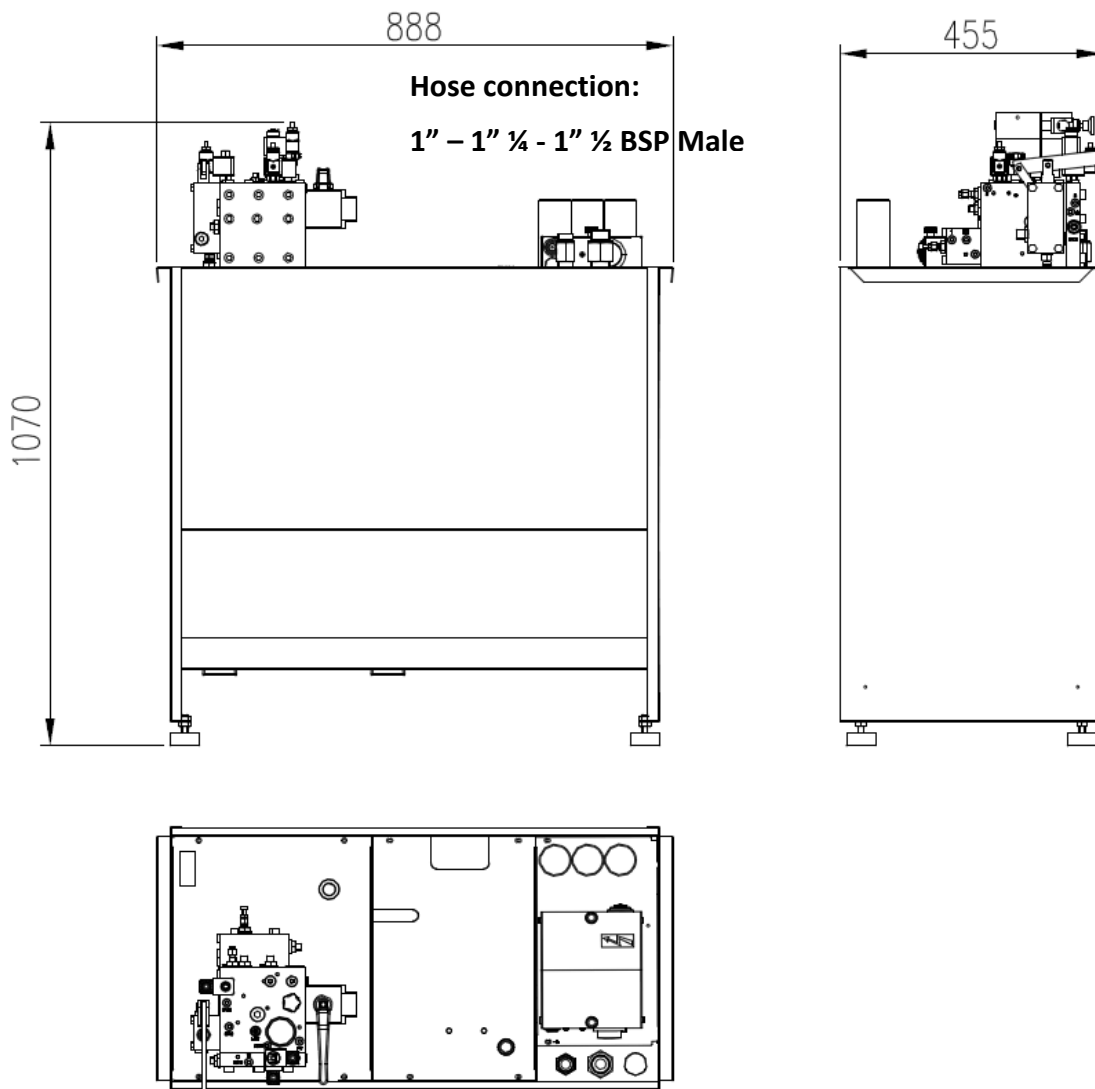

MHY 15.0 with LRV-1 valve power unit data

MOTOR POWER [kW]	OIL FLOW [l/m]	Min oil volume [l]	Working oil volume [l]	Max oil volume [l]
$3 \leq K_w \leq 24$	$35 \leq l/m \leq 250$	45	150	195

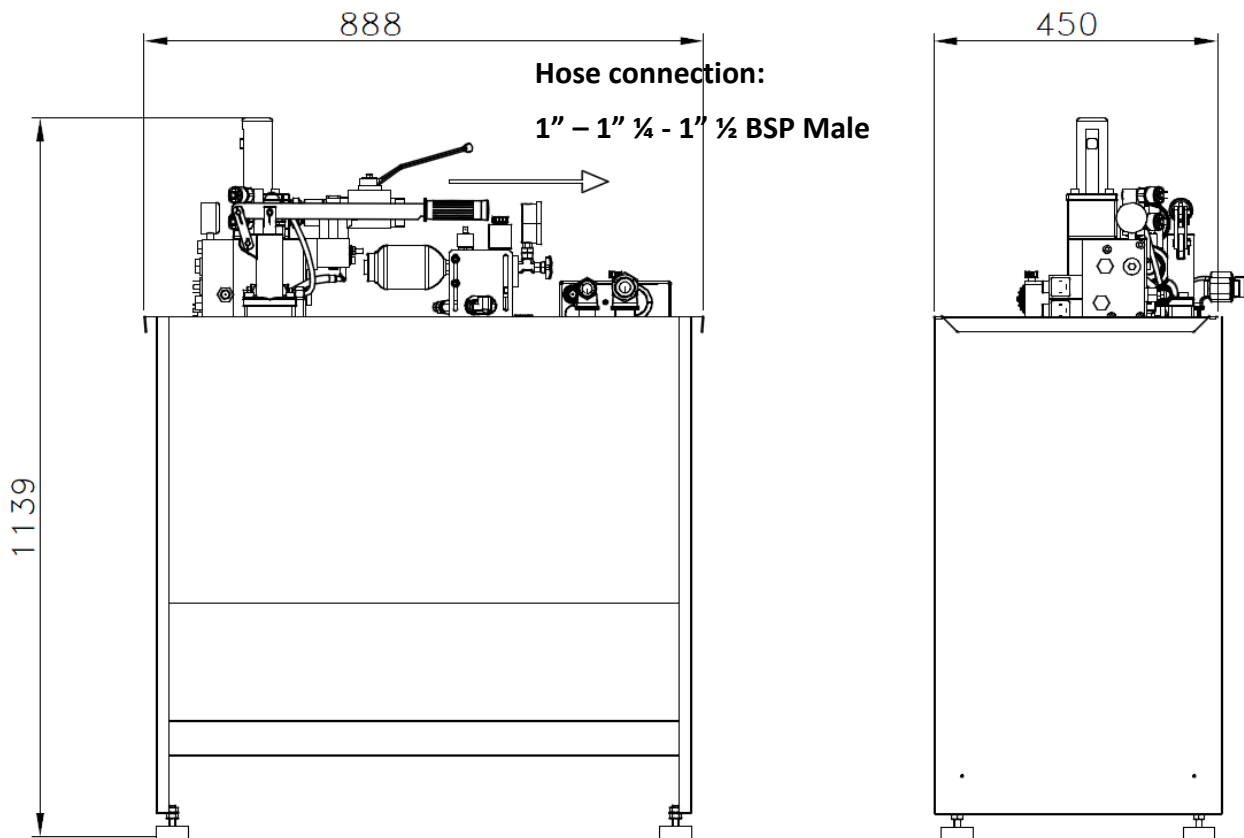

MHY 15.0 with iValve power unit data

MOTOR POWER [kW]	PUMP FLOW [l/m]	Min oil volume [l]	Working oil volume [l]	Max oil volume [l]
$3 \leq K_w \leq 24$	$35 \leq l/m \leq 250$	45	150	195

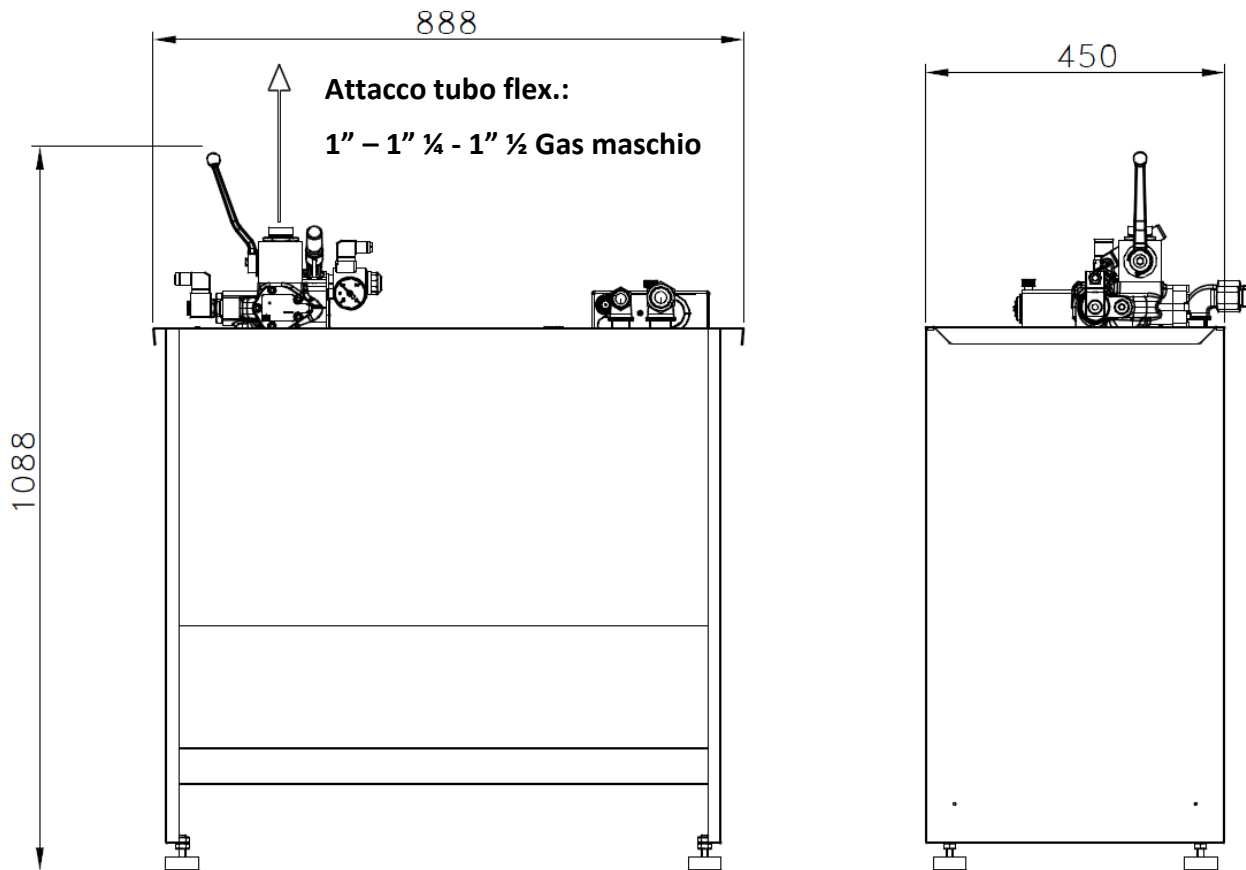

MHY 15.0 with EV100 valve power unit data

MOTOR POWER [kW]	PUMP FLOW [l/m]	Min oil volume [l]	Working oil volume [l]	Max oil volume [l]
$3 \leq K_w \leq 24$	$35 \leq l/m \leq 250$	45	150	195

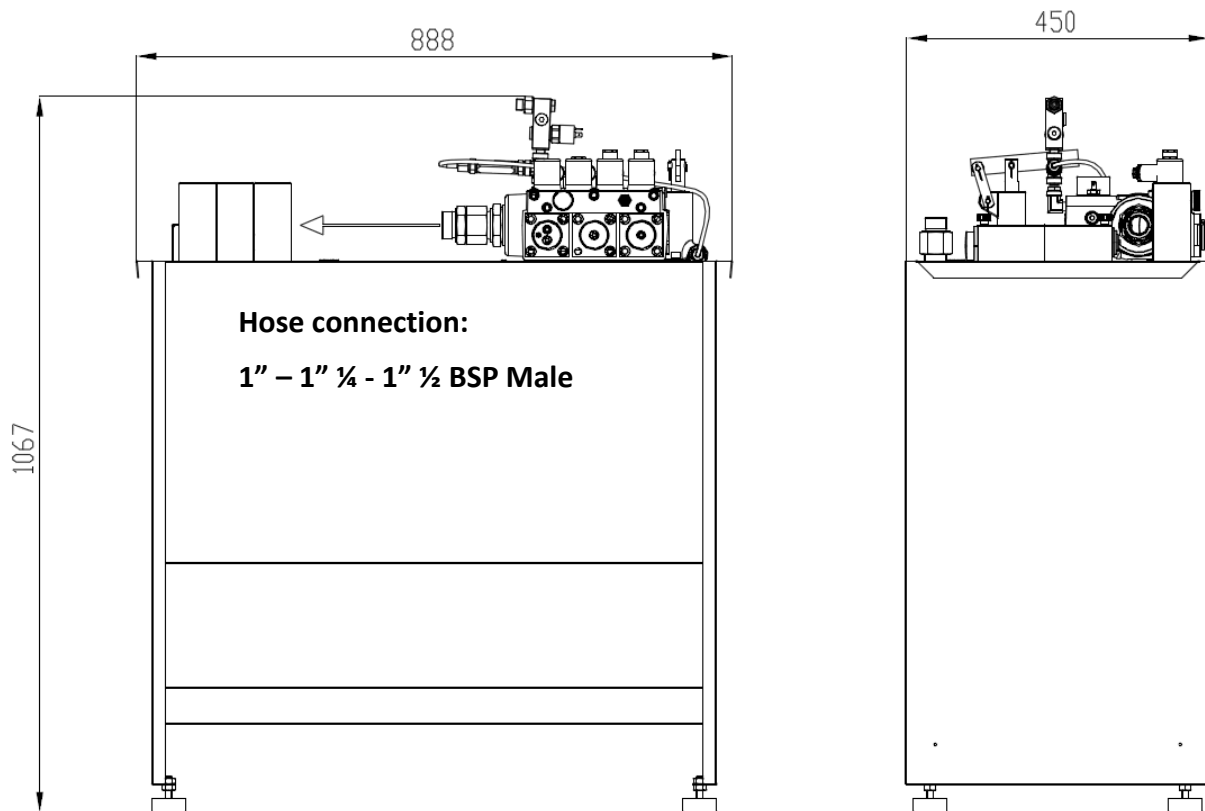

MHY 15.0 with H250e electronic valve power unit data

MOTOR POWER [kW]	PUMP FLOW [l/m]	Min oil volume [l]	Working oil volume [l]	Max oil volume [l]
$3 \leq K_w \leq 24$	$35 \leq l/m \leq 250$	45	150	195

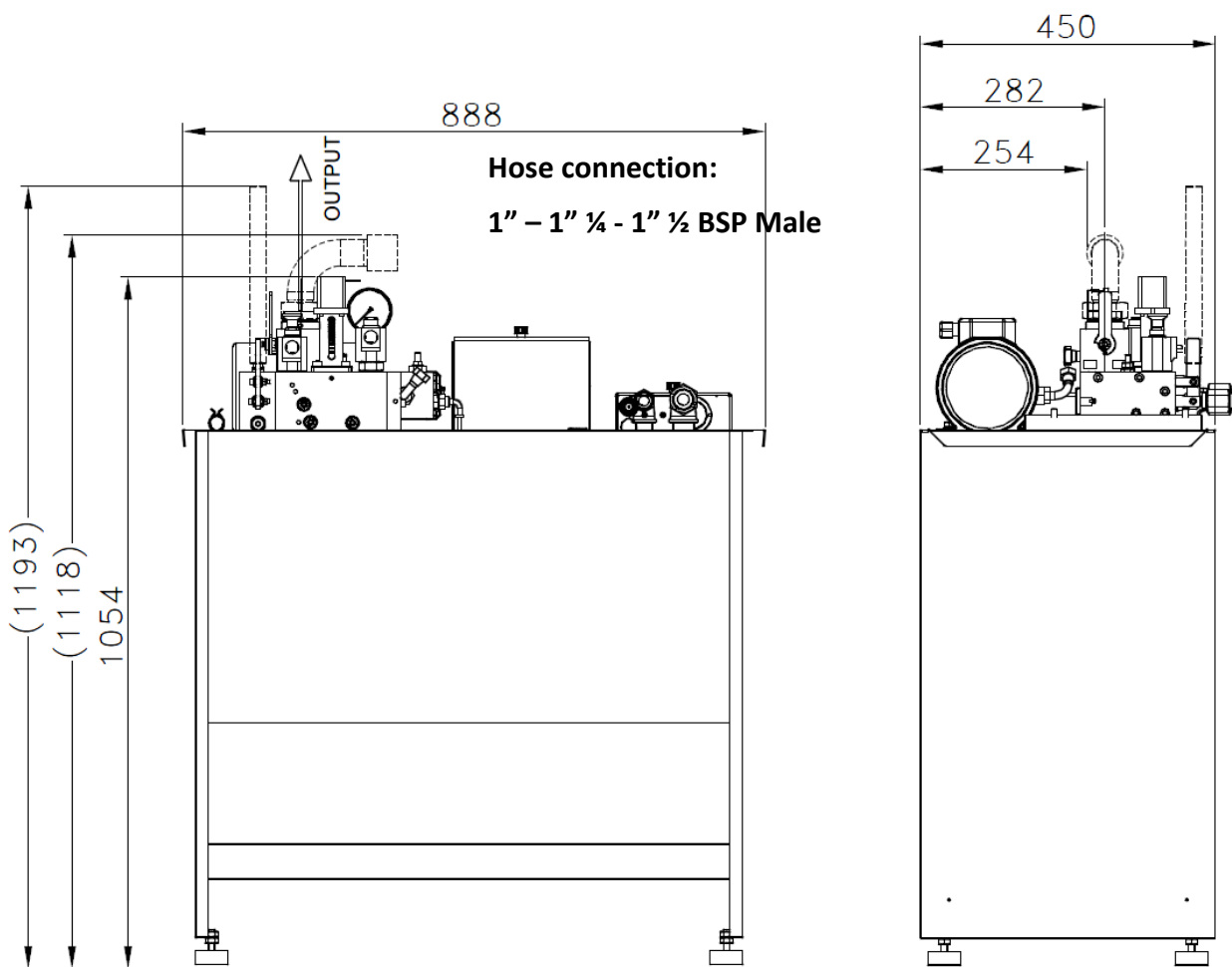

MHY 25 with H300 and H300S valve power unit data

MOTOR POWER [kW]	PUMP FLOW [l/m]	Min oil volume [l]	Working oil volume [l]	Max oil volume [l]
$3 \leq Kw \leq 29$	$35 \leq l/m \leq 250$	100	240	340

Hose connection:

1" - 1" ¼ - 1" ½ BSP Male

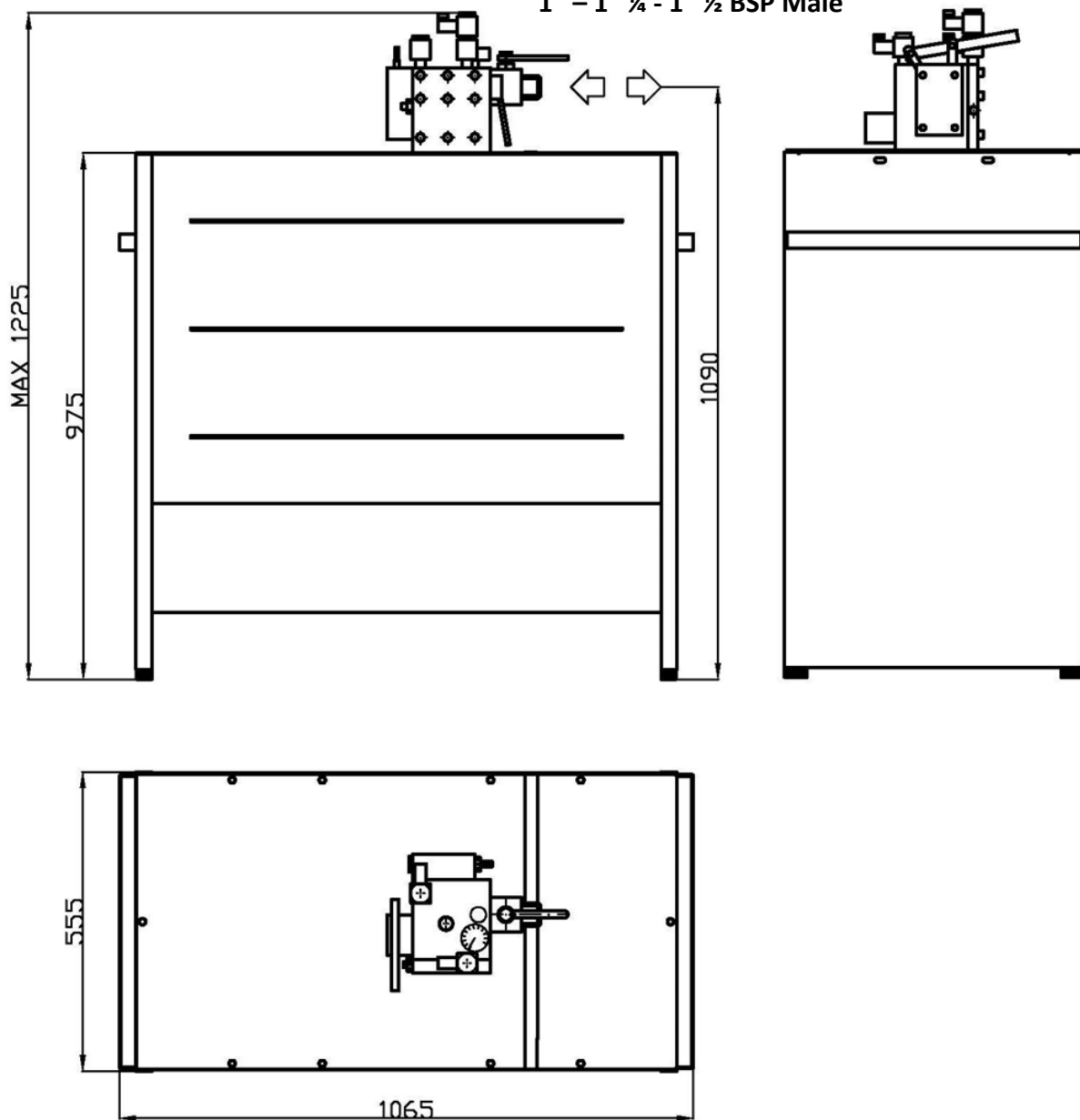

MHY 25 with LRV-1 electronic valve power unit data

MOTOR POWER [kW]	PUMP FLOW [l/m]	Min oil volume [l]	Working oil volume [l]	Max oil volume [l]
$3 \leq Kw \leq 29$	$35 \leq l/m \leq 500$	100	240	340

Hose connection:

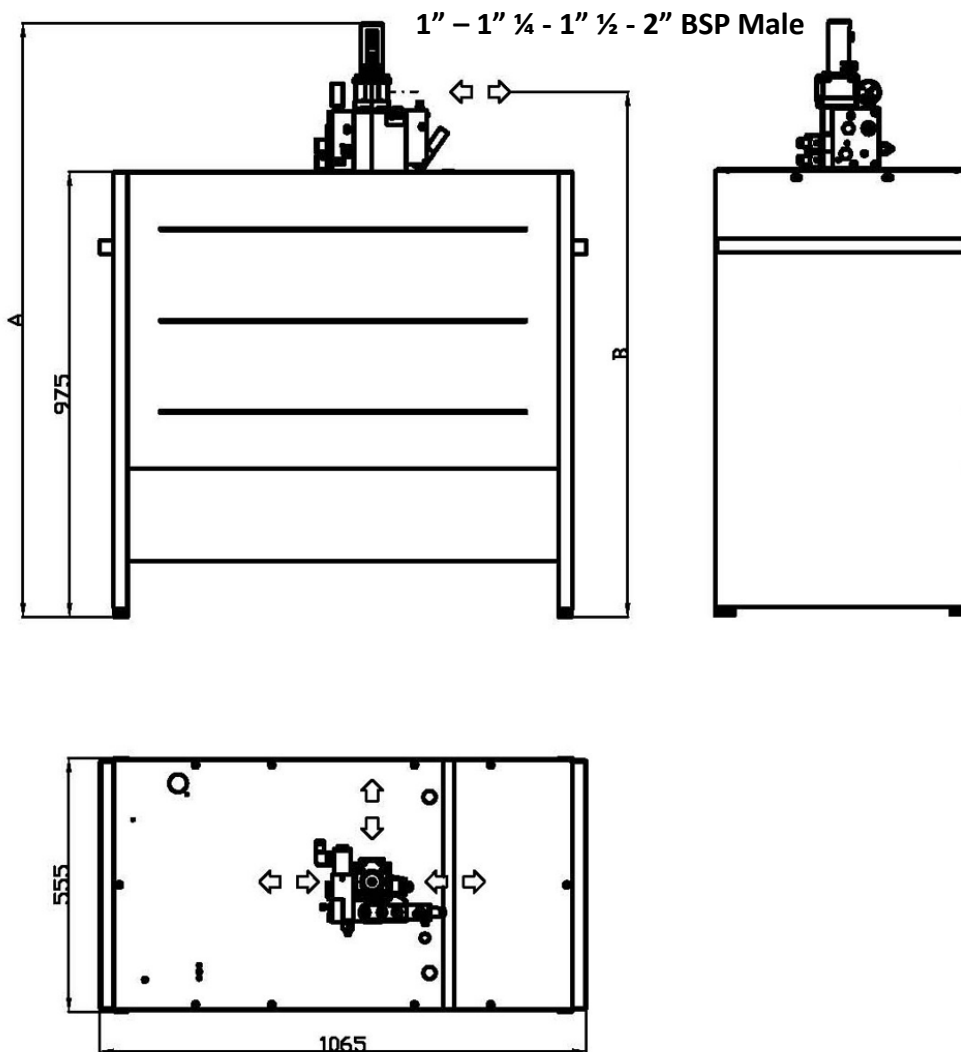

mhy25_clrv.jpg

PUMP FLOW	VALVE TYPE	A mm	B mm
$35 \leq l/min \leq 250$	LRV-1 175	1300	1150
$251 \leq l/min \leq 500$	LRV-1 350	1330	1175

MHY 25 with iValve electronic valve power unit data

MOTOR POWER [kW]	PUMP FLOW [l/m]	Min oil volume [l]	Working oil volume [l]	Max oil volume [l]
$3 \leq K_w \leq 29$	$35 \leq l/m \leq 500$	100	240	340

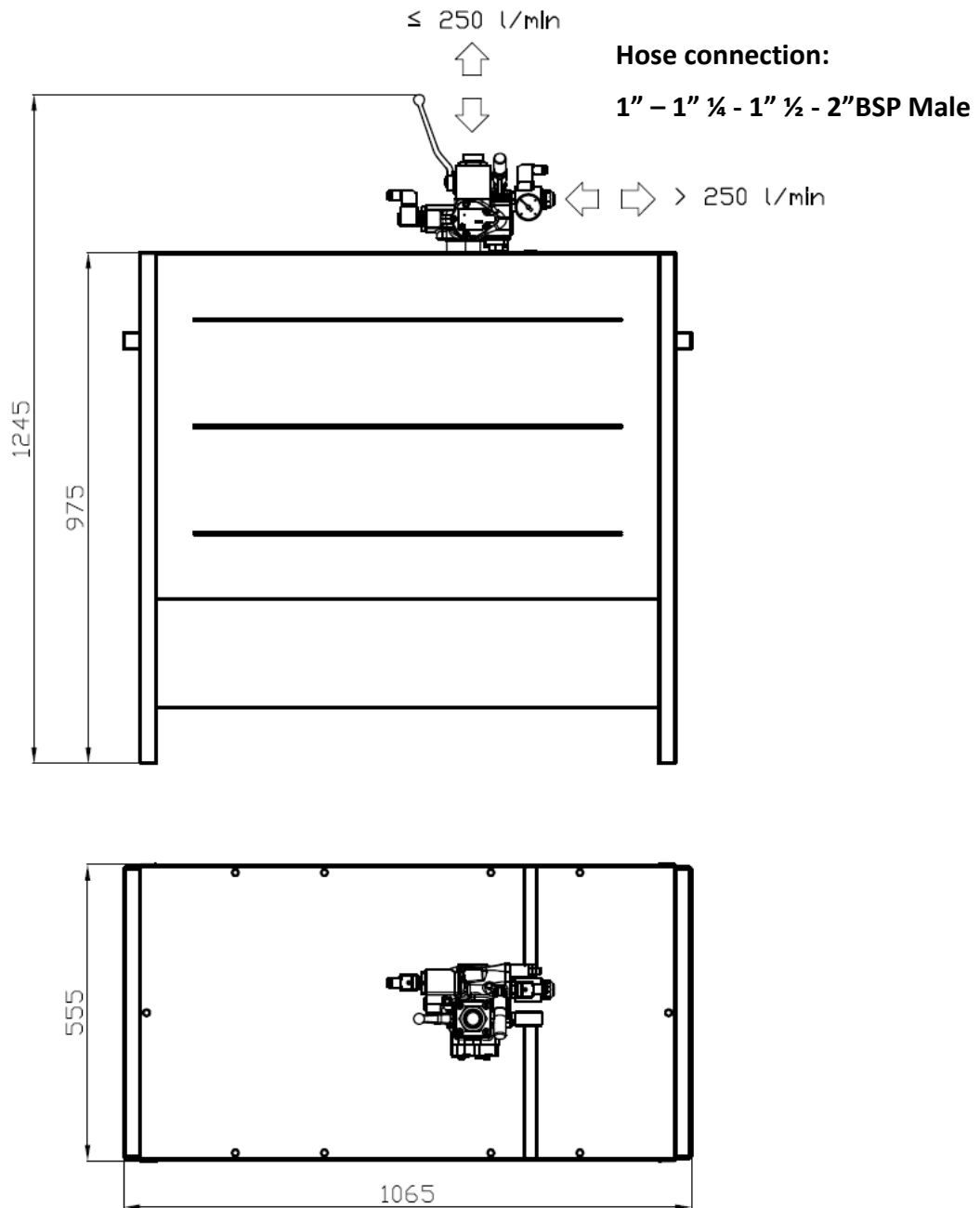

MHY 25 with EV100 valve power unit data

MOTOR POWER [kW]	PUMP FLOW [l/m]	Min oil volume [l]	Working oil volume [l]	Max oil volume [l]
$3 \leq K_w \leq 29$	$35 \leq l/m \leq 500$	100	240	340

Hose connection:

1" - 1" ¼ - 1" ½ - 2" BSP Male

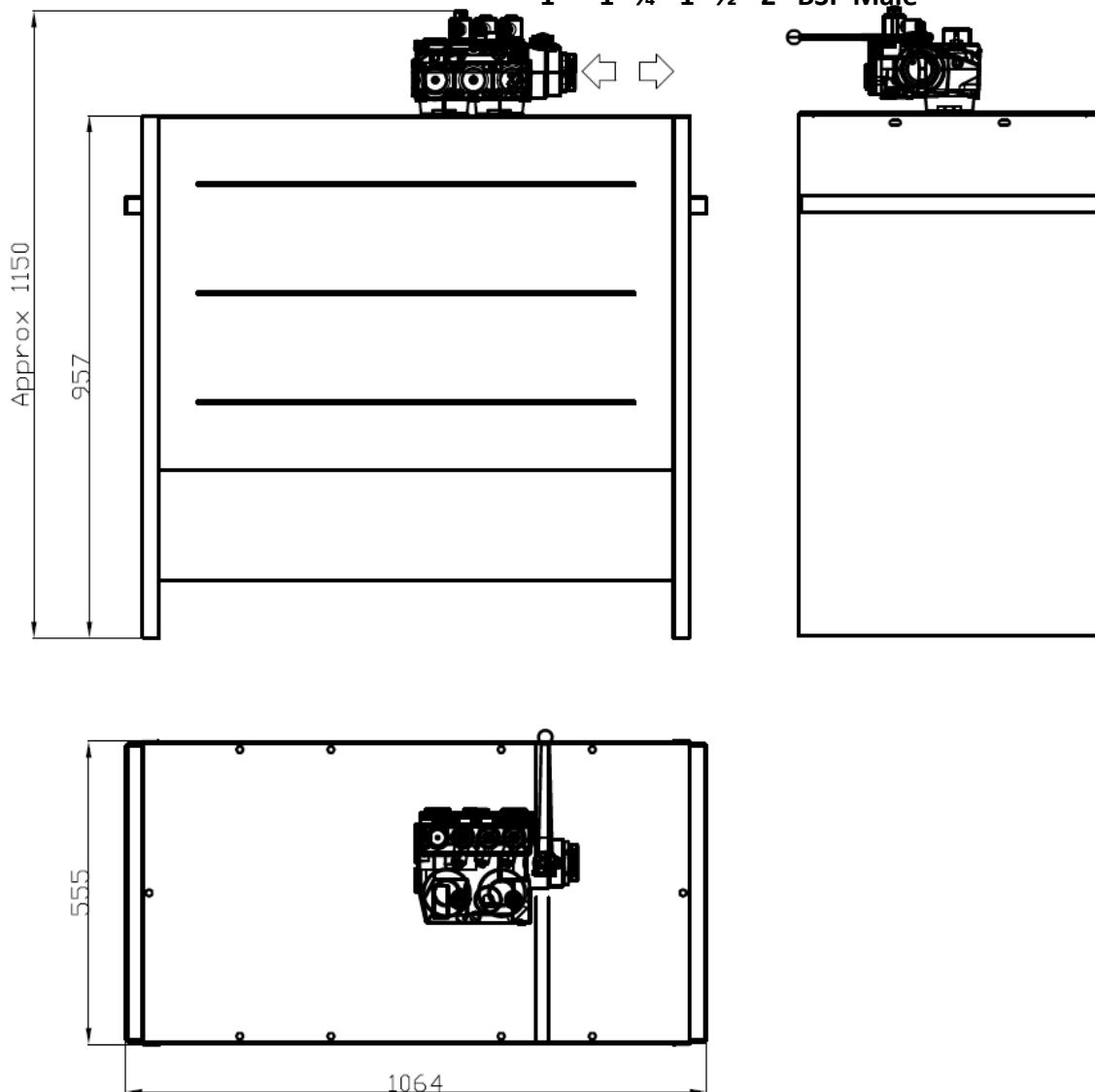

MHY 37 with H300 and H300S valve power unit data

MOTOR POWER [kW]	PUMP FLOW [l/m]	Min oil volume [l]	Working oil volume [l]	Max oil volume [l]
$3 \leq K_w \leq 29$	$35 \leq l/m \leq 250$	280	370	650

Hose connection:

1" - 1" ¼ - 1" ½ BSP Male

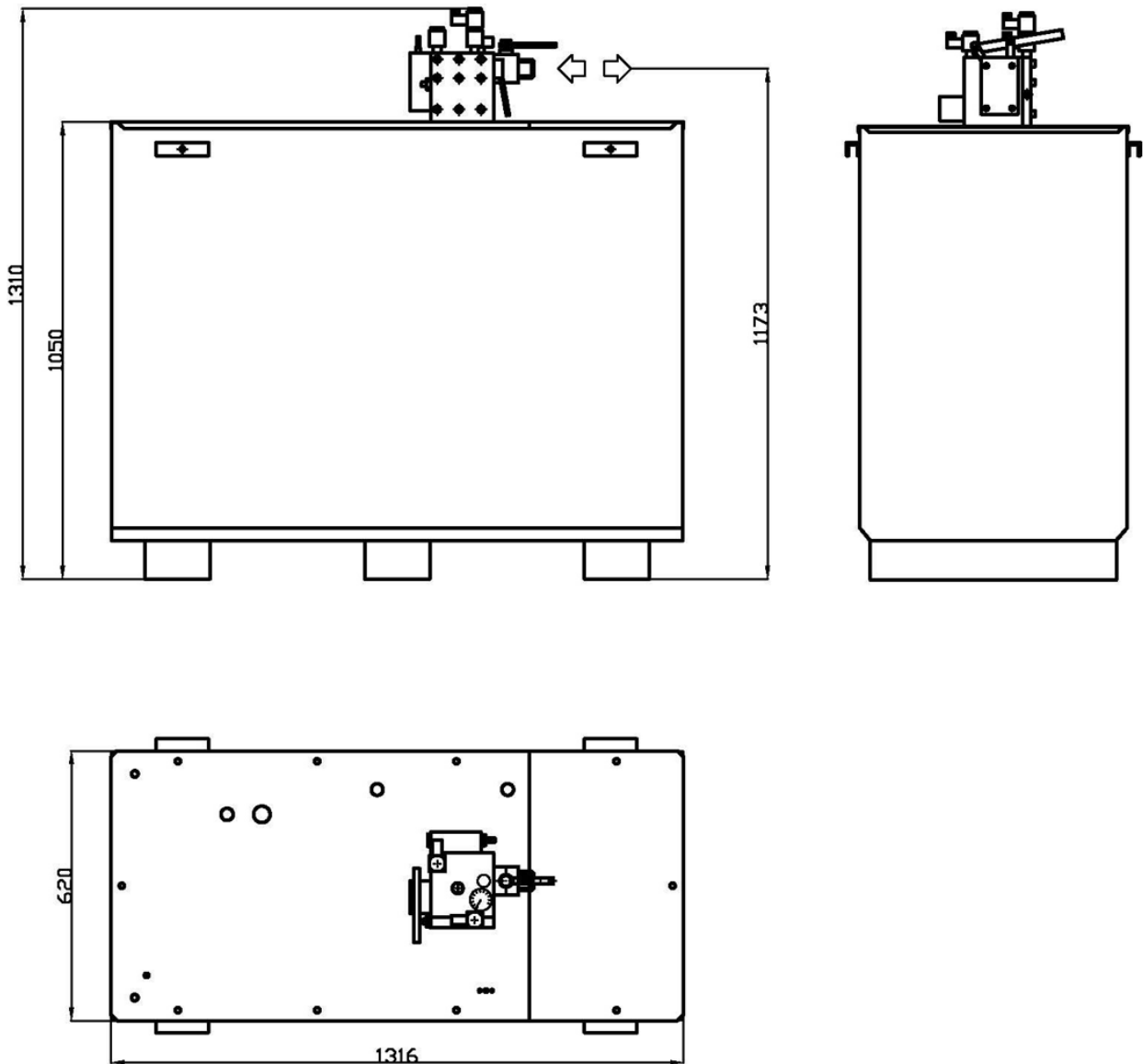

MHY 37 with LRV-1 electronic valve power unit data

MOTOR POWER [kW]	PUMP FLOW [l/m]	Min oil volume [l]	Working oil volume [l]	Max oil volume [l]
$3 \leq Kw \leq 60$	$35 \leq l/m \leq 650$	280	370	650

Hose connection:

1" - 1" ¼ - 1" ½ - 2" BSP ale

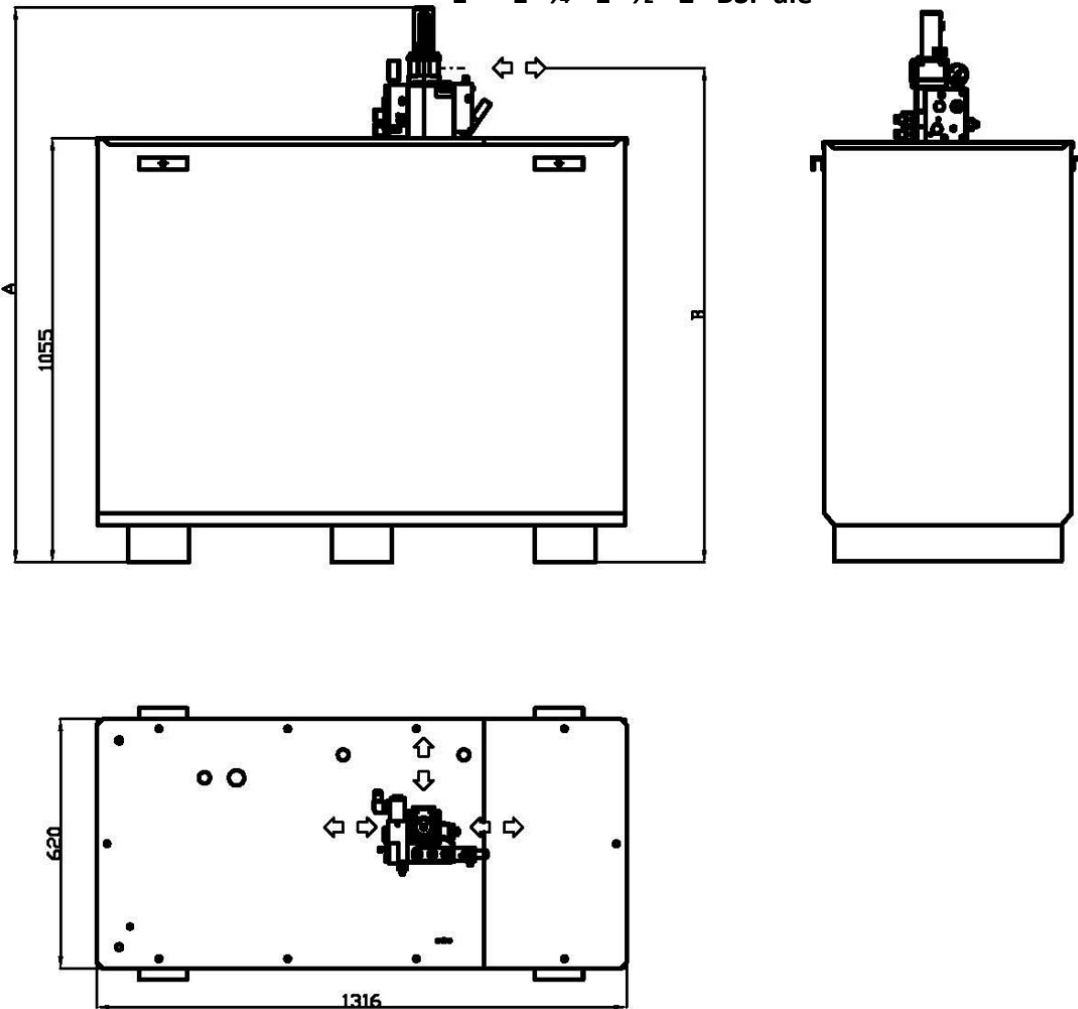

mhy37_clrv.jpg

PUMP FLOW	VALVE TYPE	A mm	B mm
$35 \leq l/min \leq 250$	LRV-1 175	1380	1230
$251 \leq l/min \leq 500$	LRV-1 350	1410	1255
$501 \leq l/min \leq 650$	LRV-1 700	1483	1320

MHY 37 with iValve electronic valve power unit data

MOTOR POWER [kW]	PUMP FLOW [l/m]	Min oil volume [l]	Working oil volume [l]	Max oil volume [l]
$3 \leq K_w \leq 47$	$35 \leq l/m \leq 500$	280	370	650

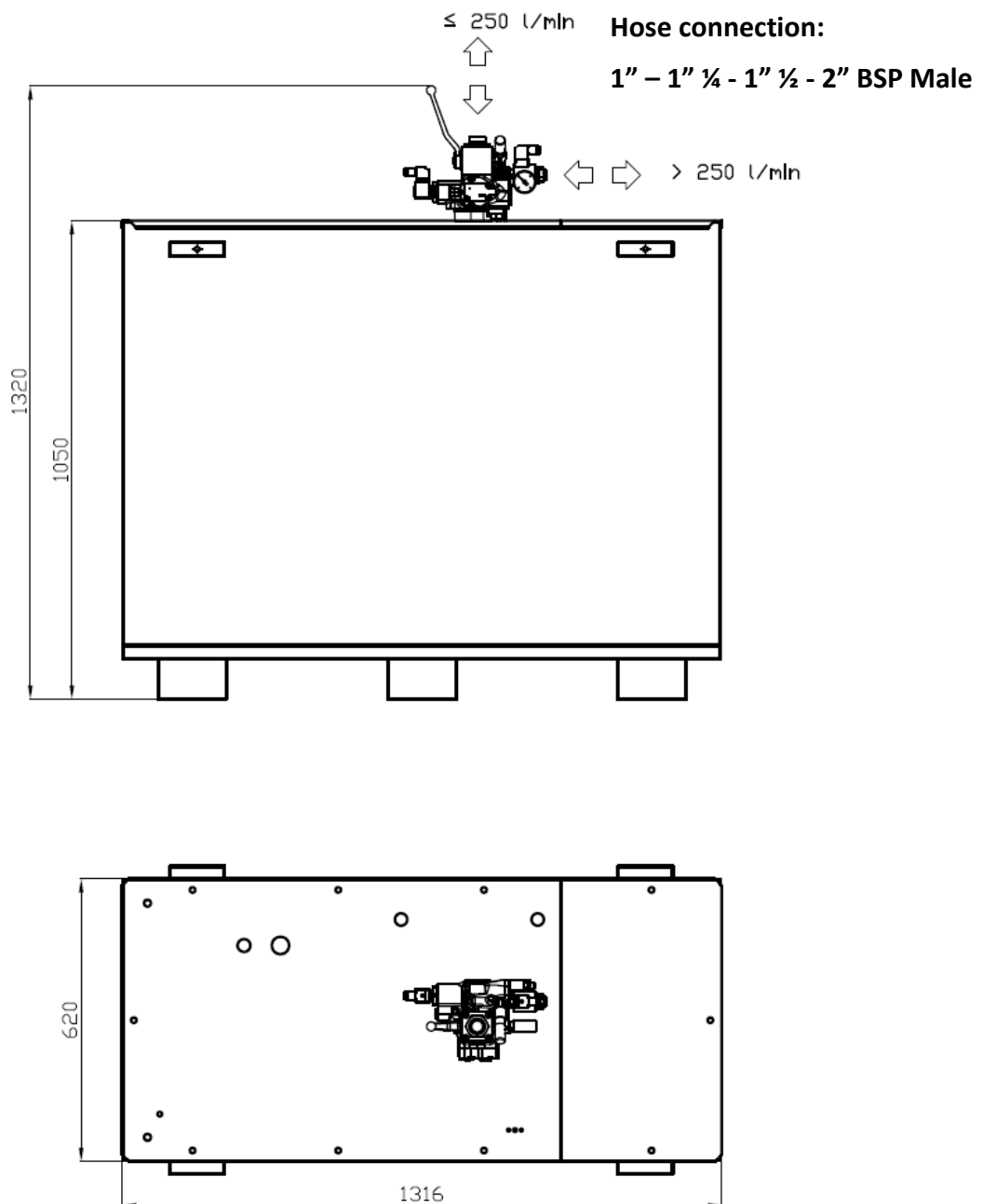

MHY 37 with EV100 valve power unit data

MOTOR POWER [kW]	PUMP FLOW [l/m]	Min oil volume [l]	Working oil volume [l]	Max oil volume [l]
$3 \leq Kw \leq 60$	$35 \leq l/m \leq 650$	280	370	650

Hose connection:

1" - 1" ¼ - 1" ½ - 2" BSP Male

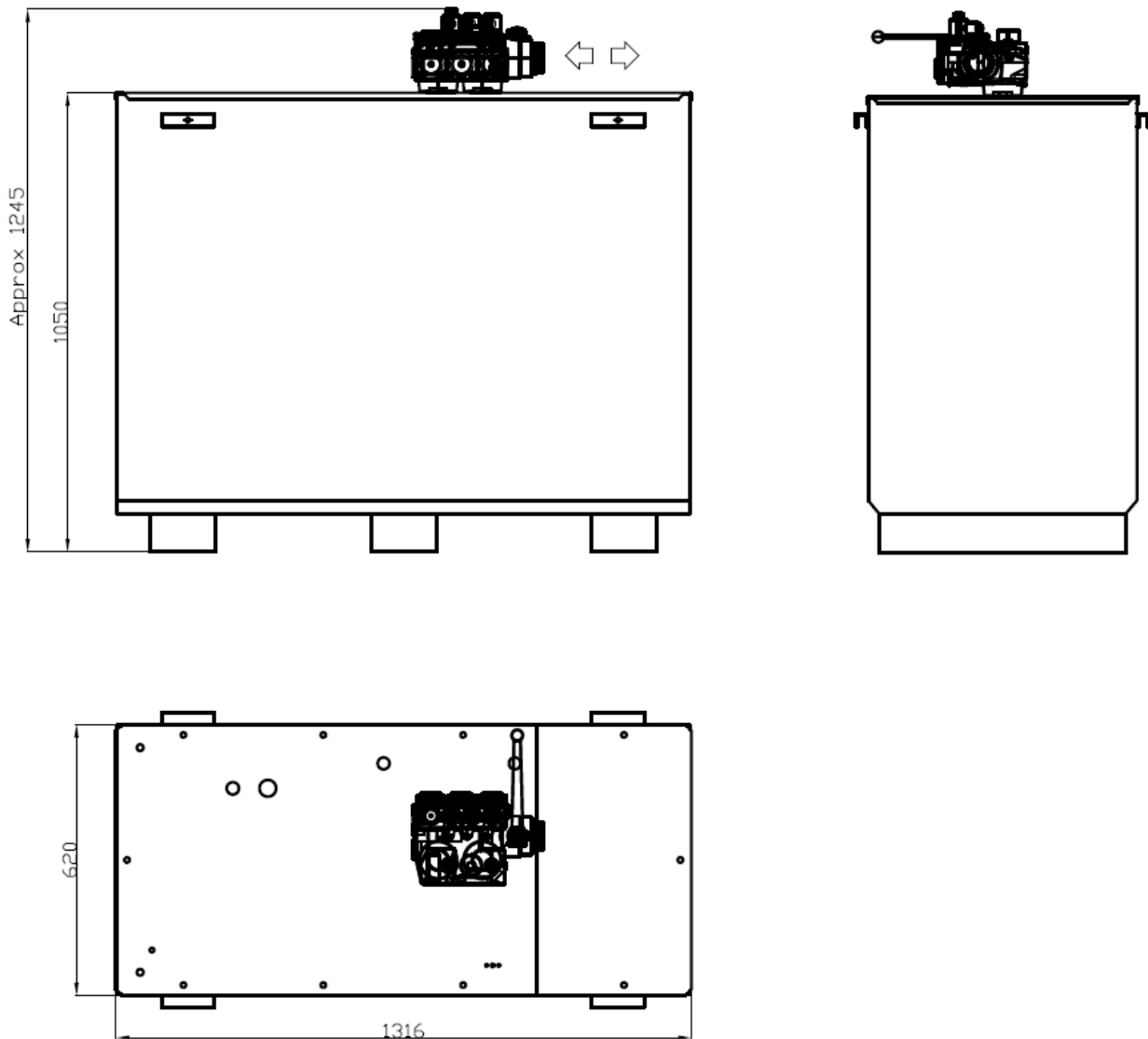

Auxiliary tank according to EN 81.20

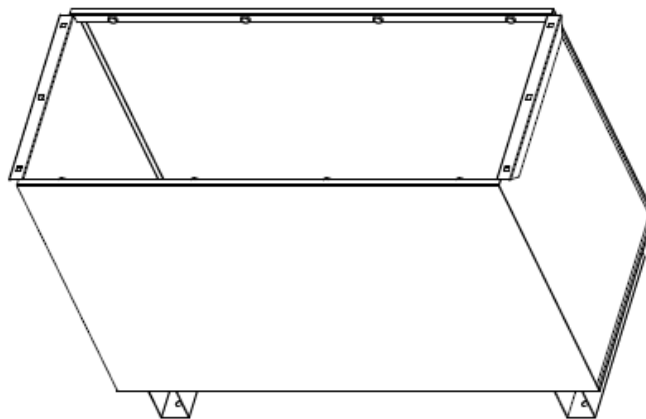
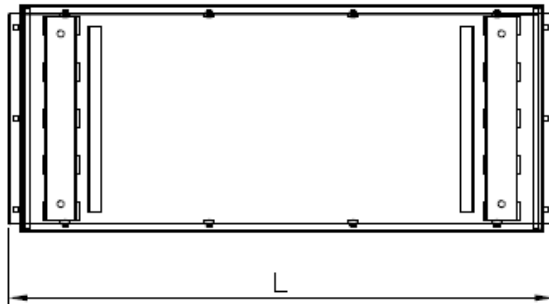
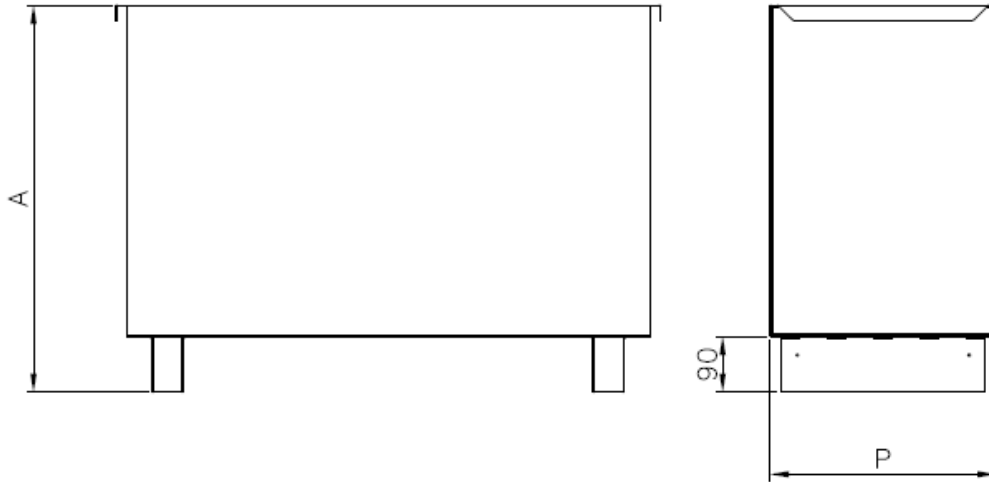

POWER UNIT	CODE	CAPACITY LITERS	L mm	A mm	P mm	WEIGHT Kg
MHY8.0	H000308AA-A0-ASS	130	880	625	365	21,9
MHY15.0	H000311AA-A0-ASS	210	951	625	495	27,3
EPOXY PAINTED RAL 5008						